

GMI

INNOVATION IN TECHNOLOGY FOR

AIRCRAFT MAINTENANCE

Composite & Metallic Structures, Solution Engineering, Training

9 Rue Buffault 75009 Paris France

Tel : (33) 1 42 82 11 44 Fax : (33) 1 42 82 98 38

Email : gmi.aero@wanadoo.fr

EQUIPMENT FOR VERY LARGE REPAIRS BLANKETS & POWER BOOSTERS 3 PHASES CONTROL MULTI ZONES 2 to 6



V: 050211

Exit

Enter

SYSTEMS FOR VERY LARGE REPAIRS

HONEYCOMB & SKIN REBONDING

POWERING - HEATING BLANKETS - ADVANCED CONTROL

Repairing very large structures of many square meters by bonding honeycomb core or a pre-cured skin is a specific problem in terms of heating means and temperature control.

It requires expertise and special equipment.

Typically, this problem is encountered in the repair of Motor parts like Cowlings, Reversers, Transcowl,...

COMPLETE ENGINEERED SYSTEM

GMI has a thorough experience in handling such a problem.

We have engineered a system as a family of equipment for powering heating systems and to control the distribution of temperature with guaranteed specification respect and safety.

Such a system is built as :

- A set of Heating Blankets, designed to fit a specific part (cowling, transcowl,...)

- A dedicated Process (Heat, Vacuum, Electrical, Bonding) Monitoring and Control Unit (ANITA Multizone Bonder)

- An Interface for Power Driving the Heating Blankets as A Power Three Phase Booster

We will review successively each unit to describe their particular features.

TWO BASIC SOLUTIONS

We will then present our 2 basic solutions as a core for specific adaptation to the customer problem:

- 1 - Two Zone Power Booster, Standard ANITA, Flat or Contoured Blankets (Three Phases),

- 2 - Four to Six Zone Power Booster, Multi Zone Control ANITA, Large Contoured Blankets



SPECIAL HEATING BLANKETS

Generally the blankets are very large, covering more than two square meters (ten or twenty and more square feet).

The technology for manufacturing such blankets calls for implementation of three techniques :

- A THREE PHASE DESIGN

Blankets of a surface of two square meters will require generally a power of more than ten thousands watts. Consequently, GMI has a technology to design the internal wiring of the blankets in Three Phases to reduce the amperes as it is logical and also to operate with safety.

- A MULTI -INDEPENDANT ZONE DESIGN

To have a better control of temperature, the electrical wiring has to be sketched in independent zones corresponding as much as possible to the different cases of thermal reactions as revealed by the structure.

- SHAPED TO NON CONFORMABLE PARTS

The structures covered by the blanket are generally not flat and non conformable. The heating blankets must be designed shaped. GMI uses a proprietary technique to design and lay up the electrical circuits to get a mat with a shaped heating surface.

THREE PHASE POWER BOOSTERS

The power Booster is the interface between the Heat Process Control Unit, ANITA, and the Blankets.

The Booster is powered individually under Three Phase Voltage. It is equipped with high power three phase solid state switches to power the heating zones of the blankets. The booster is under the control of the ANITA.

According to the power it can handle, the Booster is built in an easy transportable Case or as a very convenient Bench.

The Booster is equipped with all the safety circuits necessary.

With the Booster has Two Zones only, it is built in a Transportable Case. When it requires 4 to 6 zones, it is designed in a Rolling Bench.

The following graphic illustrates the Booster Principle in the case of a 2 zone Blanket Control. The principle is the same for 6 zones.

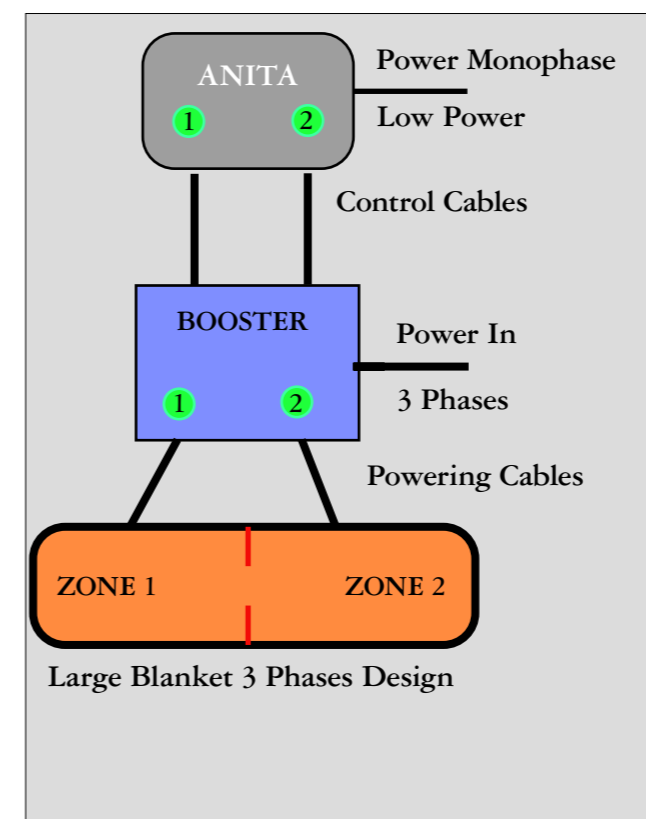

MULTI ZONE (4 to 6) CONTROL ANITA

We will consider the two cases : Two zone control or Four or 6 Zone Control.

The Two Zone Control ANITA

In this case, the problem is solved by using a standard ANITA. The Bonder is able to handle independently two electrical heating zone blankets. The choice is for an ANITA NG or OT model. Please refer to appropriate chapter for full description.

The Four or Six Zone Control ANITA

Control Handling of up to Six Zones need a special Control Bonding Unit. The equipment is built around the core of the 2 zone Standard ANITA OT and is adapted to get the capability for controlling a six zone booster.

Specifications

- **Presentation** : the unit appears as a standard ANITA OT (please refer to appropriate chapter for full description).

- **Operating Procedures** : the unit is programmed, is set to operate and is PC supervised as a standard ANITA OT. Again please refer to ANITA OT chapter for full description.

- **Connection to Booster** : The Mult zone ANITA is designed on the connection point of view to be linked easily to the booster bench. Positioned on top of the Bench it is powered by it and connects directly to the power circuits by appropriate cables from the bench.



A 6 zone Control Unit ANITA appears small and is easily positioned on the bench. It drives the power circuits wired inside the booster bench.

BOOSTER TWO ZONES 16KW



SPECIFICATIONS

- Two zone interface
- Three phase powering 380 or 480 volts according to request
- Power : 16 Kwatts -
- Fully compatible with our ANITA Bonding Consoles models NG or OT (see chapter ANITA)
- Ground fault switch and Emergency stop mounted
- Dimensions: 600 x 250-x 250 mm
- Weight: 10 Kg
- Delivered complete with power in cable and 2control cables, and User and Service Manual

APPLICATIONS :

- Control of Three Phase Heating Systems : Blankets, Radiant panels .
- Suitable for powering our Blankets for CoreCows

If the solution needs the control of simultaneously 2 set of Blankets 2 zones each

To Order

- P/N: GMIANB102 ; 16 KW - 380 Volts
- P/N: GMIANB103 ; 16 KW - 480 Volts

Always reconfirm 380 or 480 Volts and all other relevant electrical characteristics of your installation .

Other models are available according to power.

Above 16 kW the booster is designed in a rolling bench, see following paragraph. Please consult us for specific adaptation.

BOOSTER SIX ZONES up to 60 KW



SPECIFICATIONS

- Six independent power circuits,
- Three phase powering 380 or 480 volts according to request
- Designed as a rolling bench. Power : 40 to 60 Kwatts according to requests.
- Dimensions : Width 800 mm; Depth : 600 mm; Height : 1200 mm
- Weight : approx : 50 Kg
- Controlled by ANITA OT6Z.
- ANITA Control Unit can be easily and steadily installed on top of the bench .
- Power circuits :six power relays and fuses are installed inside ; access is made by two doors and maintenance is thus easy.
- Protection for Ground Fault detection mounted ..
- Additional Thermocouple Monitoring Module : mounted as a drawer a module allows the connection of 12 thermocouple to be monitored by ANITA ,
- High Limit Independent Module : A twelve thermocouple unit is mounted also as a drawer to supervise high temperature hot spots and to cut power if necessary.

APPLICATIONS :

- Control of Three Phase Heating Systems : Blankets, Radiant panels .
- Suitable for powering our Blankets for CoreCows, Transcowl, other Large Parts... ; either 2 blankets of 3 zones each or 3 blankets of 2 zones each., or any other combination of large blankets.

HOW TO BUILD YOUR SYSTEM SOLUTION ?

Select the proposed solution according to the typical application you will have to implement in regular repair production

TWO ZONE BLANKET CONTROL

Case A) 1 Blanket 2 zones or 2 Blankets 1 zone

In case of control of 1 Blanket of 2 zones or 2 blankets of 1 Zone each, ...the system builds with :

SYSTEM COMPOSED OF ..	P/N
One standard ANITA NG or OT	if NG .. P/N= GMING9201 if OT.. P/NGMIOT9701 see ANITA chapter for details.
One Booster 2 zones 16 Kw -Three Phase	- Under 380 Volts P/N = GMIANB102 - Under 480 Volts P/N = GMIANB103
Heating Blankets	To design if specific If standard flat blankets , see our list of standard products in following pages If Corecowl, Transcowl applications, see our standard product list in following pages ; if not available in our list , a design is possible by GMI specific engineering services

Case B) 2 Blankets 2 Zones , a Total of 4 Zones UP TO 32 KW

In case of control of simultaneous control of 2 blankets of 2 Zones each, and thus of a total of 4 zones, the system can be built by using TWO systems as above in parallel .

This solution can be useful if the use of 4 heating zones is scarce and flexibility is a must . In this case , the ANITA Bonding Console remains standard and can be used for classical repairs with monophasic blankets.

In case the application is of frequent need, a solution of a Bench Booster 4 zones is to be preferred. See the following solution illustrated in following..

FOUR ZONE BLANKET CONTROL 40 KW

In case of control of simultaneous control of 2 blankets of 2 Zones each or in general of a total of 4 zones, the system builds with :

SYSTEM COMPOSED OF ..	P/N
One ANITA 4 ZONES	P/N : GMIO4Z
One Booster Bench 4 zones output 40Kw -Three Phases	- Under 380 Volts P/N = GMIPB04Z-380 - Under 480 Volts P/N = GMIPB04Z-480
Heating Blankets	To design if specific If standard flat blankets , see our list of standard products in following pages If Corecowl, Transcowl applications, see our standard product list in following pages ; if not available in our list , a design is possible by GMI specific engineering services

In all cases a specific adaptation can be made in terms of Power and Voltage.

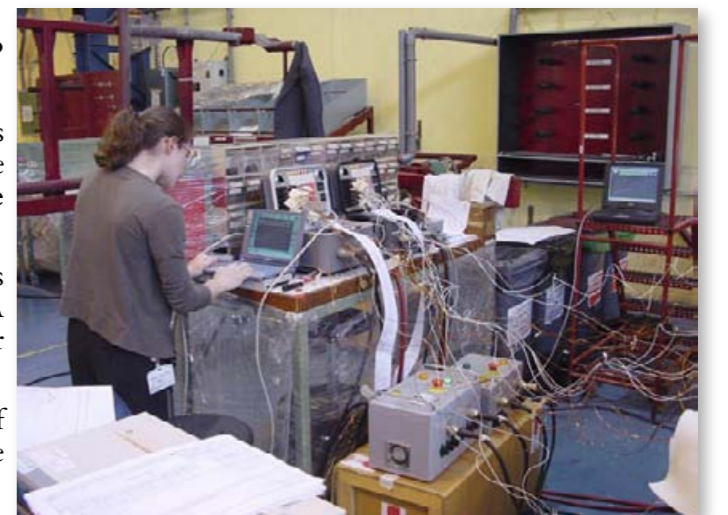

Preparation of a set up of 2 boosters 2 zones (down on photo) controlled by 2 ANITA OT Standard(up on photo).

SIX ZONE BLANKET CONTROL 60 KW

In case of control of simultaneous control of 2 blankets of 3 Zones each or in general of a total of 6 zones, the system builds with :

SYSTEM COMPOSED OF ..	P/N
One ANITA 6 ZONES	P/N : GMIOT-6Z
One Booster Bench 6 zones output 60Kw -Three Phases	- Under 380 Volts P/N = GMIPB06Z-380 - Under 480 Volts P/N = GMIPB06Z-480
Heating Blankets	To design if specific If standard flat blankets , see our list f standard products in foillowing pages If Corecowl, Transcowl applications, see our standard product list in following pages ; if not availablein our list , a design is possible by GMI specific engineering services

In all cases a specific adaptation can be made in terms of Power and Voltage.



A very large flat blanket . Its size needs a booster to power it . Here, a two zone booster - high power above 16 Kw - has been built as a rolling bench .

The Anita Standard for Control is positioned on top of the bench and is connectable to the circuits directly .

On the right of the bench, one can see the blue connectors to attach the powering cables to the blanket. The connectors are of a type that allow hand manipulation of high power circuits.

THREE PHASE VOLTAGE STANDARD HEATING BLANKETS UP TO 16 KW FOR LARGE SURFACE BONDING- CONNECT TO STANDARD 2 ZONE BOOSTER

These blankets connect to the GMI Power Boosters and are controlled by the ANITA console.

They are designed according a 3 phase triangle scheme

Standard Rectangular Blankets 2 ZONE Design

Example of traditionally ordered items

P/N below are given for 380 Volts ; for 480 and 220 volts, please specify at the request.

Blankets are delivered ready to use with connectors mounted to match the cables of the GMI ANITA Power Booster Standard 16 Kw (see above Booster Specifications)

Dimensions in mm	Part Number	Remarks	Total Power Watts
800 x 1500	GMIHB080150-3-380 *	2 zones 800 x 750 mm	9 400
1000 x 1000	GMIHB100100-3-380 *	2 zones 1000 x 750 mm	7 800
1000 x 1500	GMIHB100150-3-380 *	2 zone 1000 X 750 mm	11 700
1000 x 2000	GMIHB100200-3-380 *	2 zones 1000 x 1000 mm	15 600
750 x 1500	GMIHB075150-3-380 *	2 zones 750 x 750 mm	8 775
750 x 2000	GMIHB075200-3-380 *	2 zones 750 x 1000 mm	11 700
Other dimensions on request	* for 380 Volts 3 Phases Specify if 480 Volts	Consult GMI for more details and advises according to application	

REPAIR OF REVERSERS, CORECOWLS WITH SPECIFIC SHAPED BLANKETS

LARGE SURFACE BONDING WITH THREE PHASE BLANKETS

DEDICATED BLANKETS

Implementing the equipment as described in the preceding pages, GMI has thus designed specific large heating blankets fitted to the shape and surface of some parts like :

- FANCOWL REVERSERS , - TRANCOWL -REVERSERS

FANCOWL REVERSER TYPE	DESCRIPTION	BLANKETS P/N
CF6- 80 C2	A set of 3 Shaped Blankets of 2 zones Each	GMIHBFR-680- - 480 or - 380 / voltage

These blankets need the use of a Six Zone Booster and adapted ANITA 6 zones.



TRANCOWL REVERSER TYPE	DESCRIPTION	BLANKETS P/N
GE MARTIN MARIETTA	A set of 2 Shaped Blankets of 1 Zone Each	GMIHBTR-680- - 480 or - 380 / voltage

These blankets need the use of a 2 Zone Booster and a Standard ANITA OT9701.

